



Selina ICSE Solutions for Class 9 Maths Chapter 24 Solution of Right Triangles [Simple 2-D Problems Involving One Right-angled Triangle]

Exercise 24

Solution 1:

(i)

From the figure we have

$$\begin{aligned}\sin 60^\circ &= \frac{20}{x} \\ \frac{\sqrt{3}}{2} &= \frac{20}{x} \\ x &= \frac{40}{\sqrt{3}}\end{aligned}$$

(ii)

From the figure we have

$$\begin{aligned}\tan 30^\circ &= \frac{20}{x} \\ \frac{1}{\sqrt{3}} &= \frac{20}{x} \\ x &= 20\sqrt{3}\end{aligned}$$

(iii)

From the figure we have

$$\begin{aligned}\sin 45^\circ &= \frac{20}{x} \\ \frac{1}{\sqrt{2}} &= \frac{20}{x} \\ x &= 20\sqrt{2}\end{aligned}$$



Student's Favourite Academy

Shop No. 5, "Umang" Vasant Utsav C H S Ltd., Thakur Village, Kandivali E, Mumbai – 400 101 Phone : 8828132765, 9833035468
Email : favouriteacademy@gmail.com

Solution 2:

(i)

From the figure we have

$$\cos A = \frac{10}{20}$$

$$\cos A = \frac{1}{2}$$

$$\cos A = \cos 60^\circ$$

$$A = 60^\circ$$

(ii)

From the figure we have

$$\sin A = \frac{10}{10\sqrt{2}}$$

$$\sin A = \frac{1}{\sqrt{2}}$$

$$\sin A = \sin 45^\circ$$

$$A = 45^\circ$$

(iii)

From the figure we have

$$\tan A = \frac{10\sqrt{3}}{10}$$

$$\tan A = \sqrt{3}$$

$$\tan A = \tan 60^\circ$$

$$A = 60^\circ$$



Solution 3:

The figure is drawn as follows:

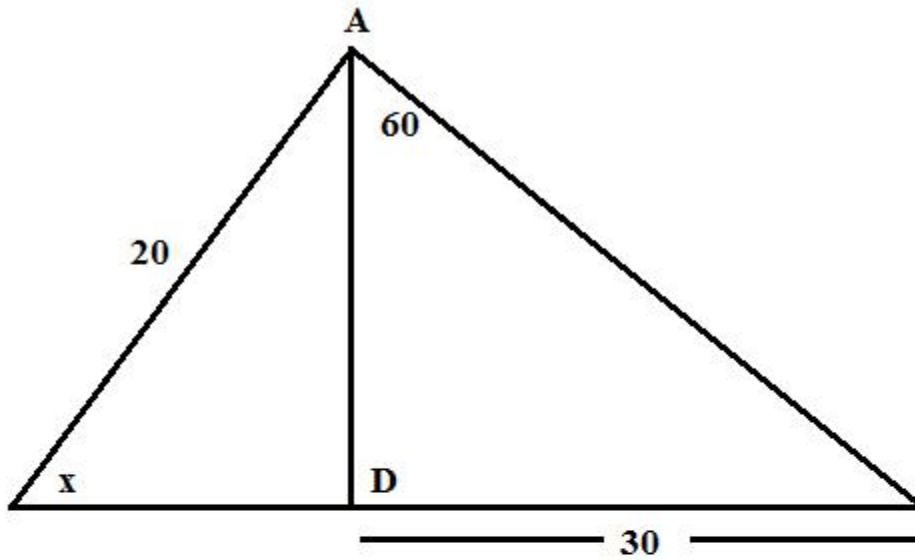

The above figure we have

$$\tan 60^\circ = \frac{30}{AD}$$

$$\sqrt{3} = \frac{30}{AD}$$

$$AD = \frac{30}{\sqrt{3}}$$

Again

$$\sin x = \frac{AD}{20}$$

$$AD = 20 \sin x$$

Now



Student's Favourite Academy

Shop No. 5, "Umang" Vasant Utsav C H S Ltd., Thakur Village, Kandivali E, Mumbai – 400 101 Phone : 8828132765, 9833035468
Email : favouriteacademy@gmail.com

$$\begin{aligned}20 \sin x &= \frac{30}{\sqrt{3}} \\ \sin x &= \frac{30}{20\sqrt{3}} \\ \sin x &= \frac{\sqrt{3}}{2} \\ \sin x &= \sin 60^\circ \\ x &= 60^\circ\end{aligned}$$

Solution 4:

(i)

From the right triangle ABE

$$\begin{aligned}\tan 45^\circ &= \frac{AE}{BE} \\ 1 &= \frac{AE}{BE} \\ AE &= BE\end{aligned}$$

Therefore $AE = BE = 50$ m.

Now from the rectangle BCDE we have

$$DE = BC = 10 \text{ m.}$$

Therefore the length of AD will be:

$$AD = AE + DE = 50 + 10 = 60 \text{ m.}$$

(ii)

From the triangle ABD we have

$$\begin{aligned}\sin B &= \frac{AD}{AB} \\ \sin 30^\circ &= \frac{AD}{100} \quad \left[\text{Since } \angle ACD \text{ is the exterior} \right. \\ &\quad \left. \text{angle of the triangle ABC} \right] \\ \frac{1}{2} &= \frac{AD}{100} \\ AD &= 50 \text{ m}\end{aligned}$$



Student's Favourite Academy

Shop No. 5, "Umang" Vasant Utsav C H S Ltd., Thakur Village, Kandivali E, Mumbai – 400 101 Phone : 8828132765, 9833035468
Email : favouriteacademy@gmail.com

Solution 5:

From right triangle ABC,

$$\tan 60^\circ = \frac{AC}{BC}$$

$$\Rightarrow \sqrt{3} = \frac{AC}{40}$$

$$\Rightarrow AC = 40\sqrt{3} \text{ cm}$$

From right triangle BDC,

$$\tan 45^\circ = \frac{DC}{BC}$$

$$\Rightarrow 1 = \frac{DC}{40}$$

$$\Rightarrow DC = 40 \text{ cm}$$

From the figure, it is clear that $AD = AC - DC$

$$\Rightarrow AD = 40\sqrt{3} - 40$$

$$\Rightarrow AD = 40(\sqrt{3} - 1)$$

$$\Rightarrow AD = 29.28 \text{ cm}$$



Student's Favourite Academy

Shop No. 5, "Umang" Vasant Utsav C H S Ltd., Thakur Village, Kandivali E, Mumbai – 400 101 Phone : 8828132765, 9833035468
Email : favouriteacademy@gmail.com

Solution 6:

We know, diagonals of a rhombus bisect each other at right angles and also bisect the angle of vertex.

The figure is shown below:

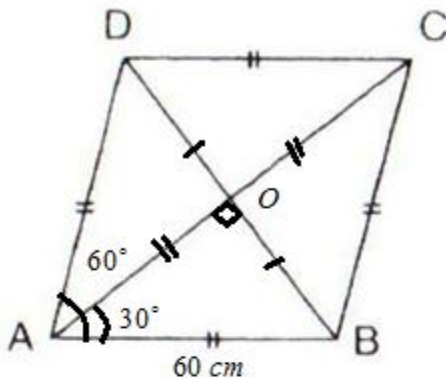

Now

$$OA = OC = \frac{1}{2}AC, OB = OD = \frac{1}{2}BD, \angle AOB = 90^\circ$$

$$\text{And } \angle OAB = \frac{60^\circ}{2} = 30^\circ$$

Also given $AB = 60\text{cm}$

In right triangle AOB

$$\begin{aligned}\sin 30^\circ &= \frac{OB}{AB} \\ \frac{1}{2} &= \frac{OB}{60} \\ OB &= 30\text{cm}\end{aligned}$$

Also

$$\begin{aligned}\cos 30^\circ &= \frac{OA}{AB} \\ \frac{\sqrt{3}}{2} &= \frac{OA}{60} \\ OA &= 51.96\text{cm}\end{aligned}$$



Student's Favourite Academy

Shop No. 5, "Umang" Vasant Utsav C H S Ltd., Thakur Village, Kandivali E, Mumbai – 400 101 Phone : 8828132765, 9833035468
Email : favouriteacademy@gmail.com

Therefore,

$$\text{Length of diagonal } AC = 2 \times OA = 2 \times 51.96 = 103.92 \text{ cm.}$$

$$\text{Length of diagonal } BD = 2 \times OB = 2 \times 30 = 60 \text{ cm.}$$



Solution 7:

Consider the figure

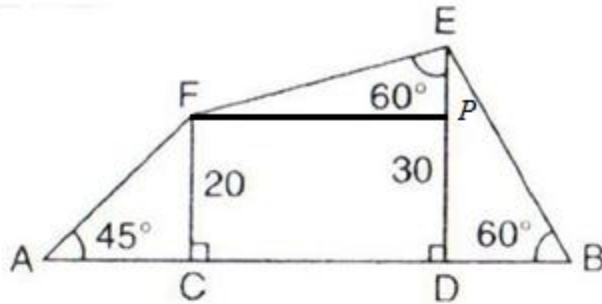

From right triangle ACF

$$\begin{aligned}\tan 45^\circ &= \frac{20}{AC} \\ 1 &= \frac{20}{AC} \\ AC &= 20 \text{ cm}\end{aligned}$$

From triangle DEB

$$\begin{aligned}\tan 60^\circ &= \frac{30}{BD} \\ \sqrt{3} &= \frac{30}{BD} \\ BD &= \frac{30}{\sqrt{3}} \\ &= 17.32 \text{ cm}\end{aligned}$$

Given $FC = 20, ED = 30$, So $EP = 10 \text{ cm}$

Therefore

$$\begin{aligned}\tan 60^\circ &= \frac{FP}{EP} \\ \sqrt{3} &= \frac{FP}{10} \\ FP &= 10\sqrt{3} \\ &= 17.32 \text{ cm}\end{aligned}$$



Student's Favourite Academy

Shop No. 5, "Umang" Vasant Utsav C H S Ltd., Thakur Village, Kandivali E, Mumbai – 400 101 Phone : 8828132765, 9833035468
Email : favouriteacademy@gmail.com

Thus $AB = AC + CD + BD = 54.64$ cm.

Solution 8:

First draw two perpendiculars to AB from the point D and C respectively. Since $AB \parallel CD$ therefore PMCD will be a rectangle.

Consider the figure,



Student's Favourite Academy

Shop No. 5, "Umang" Vasant Utsav C H S Ltd., Thakur Village, Kandivali E, Mumbai - 400 101 Phone : 8828132765, 9833035468
Email : favouriteacademy@gmail.com

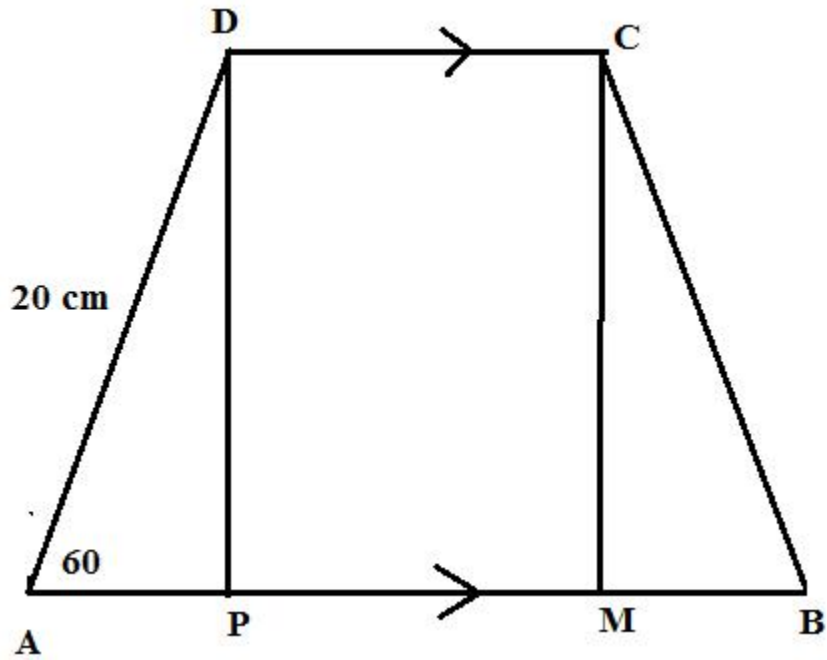



Student's Favourite Academy

Shop No. 5, "Umang" Vasant Utsav C H S Ltd., Thakur Village, Kandivali E, Mumbai – 400 101 Phone : 8828132765, 9833035468
Email : favouriteacademy@gmail.com

(i)

From right triangle ADP we have

$$\cos 60^\circ = \frac{AP}{AD}$$

$$\frac{1}{2} = \frac{AP}{20}$$

$$AP = 10$$

Similarly from the right triangle BMC we have $BM = 10$ cm.

Now from the rectangle PMCD we have $CD = PM = 20$ cm.

Therefore

$$AB = AP + PM + MB = 10 + 20 + 10 = 40 \text{ cm.}$$

(ii)

Again from the right triangle APD we have

$$\sin 60^\circ = \frac{PD}{AD}$$

$$\frac{\sqrt{3}}{2} = \frac{PD}{20}$$

$$PD = 10\sqrt{3}$$

Therefore the distance between AB and CD is $10\sqrt{3}$.



Student's Favourite Academy

Shop No. 5, "Umang" Vasant Utsav C H S Ltd., Thakur Village, Kandivali E, Mumbai – 400 101 Phone : 8828132765, 9833035468
Email : favouriteacademy@gmail.com

Solution 9:

From right triangle AQP

$$\begin{aligned}\tan 30^\circ &= \frac{AQ}{AP} \\ \frac{1}{\sqrt{3}} &= \frac{10}{AP} \\ AP &= 10\sqrt{3}\end{aligned}$$

Also from triangle PBR

$$\begin{aligned}\tan 45^\circ &= \frac{PB}{BR} \\ 1 &= \frac{PB}{8} \\ PB &= 8\end{aligned}$$

Therefore,

$$AB = AP + PB = 10\sqrt{3} + 8$$

Solution 10:

From right triangle ADE

$$\begin{aligned}\tan 45^\circ &= \frac{AE}{DE} \\ 1 &= \frac{AE}{30} \\ AE &= 30 \text{ cm}\end{aligned}$$

Also, from triangle DBE

$$\begin{aligned}\tan 60^\circ &= \frac{BE}{DE} \\ \sqrt{3} &= \frac{BE}{30} \\ BE &= 30\sqrt{3} \text{ cm}\end{aligned}$$

$$\text{Therefore } AB = AE + BE = 30 + 30\sqrt{3} = 30(1 + \sqrt{3}) \text{ cm}$$



Student's Favourite Academy

Shop No. 5, "Umang" Vasant Utsav C H S Ltd., Thakur Village, Kandivali E, Mumbai – 400 101 Phone : 8828132765, 9833035468
Email : favouriteacademy@gmail.com

Solution 11:

(i)

From the triangle ADC we have

$$\tan 45^\circ = \frac{AD}{DC}$$

$$1 = \frac{2}{DC}$$

$$DC = 2$$

Since $AD \parallel DC$ and $AD \perp EC$, ABCD is a parallelogram and hence opposite sides are equal.

Therefore $AB = DC = 2$ cm

(ii)

Again

$$\sin 45^\circ = \frac{AD}{AC}$$

$$\frac{1}{\sqrt{2}} = \frac{2}{AC}$$

$$AC = 2\sqrt{2}$$

(iii)

From the right triangle ADE we have

$$\sin 60^\circ = \frac{AD}{AE}$$

$$\frac{\sqrt{3}}{2} = \frac{2}{AE}$$

$$AE = \frac{4}{\sqrt{3}}$$



Solution 12:

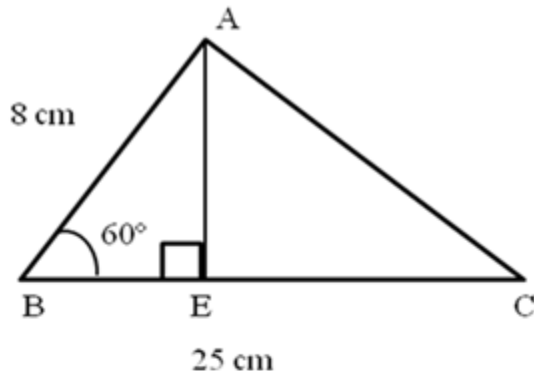

Let $BE = x$, and $EC = 25 - x$

In $\triangle ABC$,

$$\sin 60^\circ = \frac{AE}{AB}$$

$$\Rightarrow \frac{\sqrt{3}}{2} = \frac{AE}{8}$$

$$\Rightarrow AE = 8 \times \frac{\sqrt{3}}{2}$$

$$\Rightarrow AE = 4\sqrt{3} \text{ cm}$$

$$(i) BE^2 = AB^2 - AE^2$$

$$\Rightarrow BE^2 = 8^2 - (4\sqrt{3})^2$$

$$\Rightarrow BE^2 = 64 - 48$$

$$\Rightarrow BE^2 = 16$$

$$\Rightarrow BE = 4 \text{ cm}$$

$$(ii) EC = BC - BE$$

$$= 25 - 4$$

$$= 21$$

In right $\triangle AEC$,

$$AC^2 = AE^2 + EC^2$$

$$\Rightarrow AC^2 = (4\sqrt{3})^2 + 21^2$$

$$\Rightarrow AC^2 = 48 + 441$$

$$\Rightarrow AC^2 = 489$$

$$\Rightarrow AC = 22.11 \text{ cm}$$



Student's Favourite Academy

Shop No. 5, "Umang" Vasant Utsav C H S Ltd., Thakur Village, Kandivali E, Mumbai – 400 101 Phone : 8828132765, 9833035468
Email : favouriteacademy@gmail.com

Solution 13:

(i)

From right triangle ABC

$$\tan 30^\circ = \frac{AB}{BC}$$

$$\frac{1}{\sqrt{3}} = \frac{12}{BC}$$

$$BC = 12\sqrt{3} \text{ cm}$$

(ii) From the right triangle ABD

$$\cos A = \frac{AD}{AB}$$

$$\cos 60^\circ = \frac{AD}{AB}$$

$$\frac{1}{2} = \frac{AD}{12}$$

$$AD = \frac{12}{2}$$
$$= 6 \text{ cm}$$

(iii) From right triangle ABC

$$\sin B = \frac{AB}{AC}$$

$$\sin 30^\circ = \frac{AB}{AC}$$

$$\frac{1}{2} = \frac{12}{AC}$$

$$AC = 24 \text{ cm}$$



Solution 14:

Consider the figure

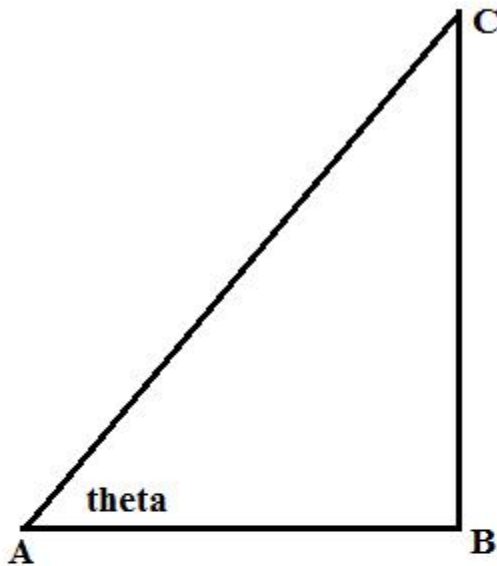

(i) Here AB is $\sqrt{3}$ times of BC means

$$\frac{AB}{BC} = \sqrt{3}$$

$$\cot \theta = \cot 30^\circ$$

$$\theta = 30^\circ$$

(ii)

Again from the figure

$$\frac{BC}{AB} = \frac{1}{\sqrt{3}}$$

$$\tan \theta = \frac{1}{\sqrt{3}}$$

$$\tan \theta = \tan 30^\circ$$

$$\theta = 30^\circ$$

Therefore, magnitude of angle A is 30°



Student's Favourite Academy

Shop No. 5, "Umang" Vasant Utsav C H S Ltd., Thakur Village, Kandivali E, Mumbai – 400 101 Phone : 8828132765, 9833035468
Email : favouriteacademy@gmail.com

Solution 15:

Given that the ladder makes an angle of 30° with the ground and reaches upto a height of 15 m of the tower which is shown in the figure below:

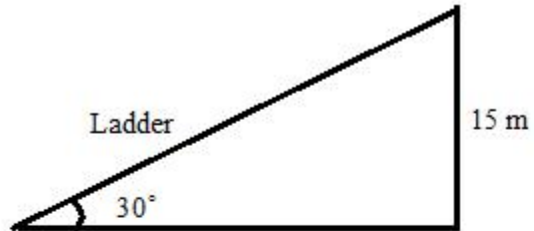

Suppose the length of the ladder is x m

From the figure

$$\frac{15}{x} = \sin 30^\circ \quad \left[\because \frac{\text{Perp.}}{\text{Hypot.}} = \sin \right]$$

$$\frac{15}{x} = \frac{1}{2}$$

$$x = 30 \text{ m}$$

Therefore the length of the ladder is 30m.



Student's Favourite Academy

Shop No. 5, "Umang" Vasant Utsav C H S Ltd., Thakur Village, Kandivali E, Mumbai – 400 101 Phone : 8828132765, 9833035468
Email : favouriteacademy@gmail.com

Solution 16:

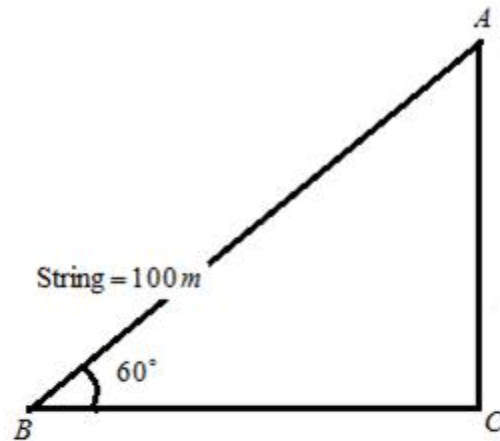

Suppose that the greatest height is x m.

From the figure

$$\frac{x}{100} = \sin 60^\circ \quad \left[\because \frac{\text{Perp.}}{\text{Hypot.}} = \sin \right]$$

$$\frac{x}{100} = \frac{\sqrt{3}}{2}$$

$$x = 86.6 \text{ m}$$

Therefore the greatest height reached by the kite is 86.6 m .



Student's Favourite Academy

Shop No. 5, "Umang" Vasant Utsav C H S Ltd., Thakur Village, Kandivali E, Mumbai – 400 101 Phone : 8828132765, 9833035468
Email : favouriteacademy@gmail.com

Solution 17:

$$(i) \text{ Let } BC = xm$$

$$BD = BC + CD = (x+20)cm$$

In $\triangle ABD$,

$$\tan 30^\circ = \frac{AB}{BD}$$

$$\frac{1}{\sqrt{3}} = \frac{AB}{x+20}$$

$$x+20 = \sqrt{3}AB \quad \dots(1)$$

In $\triangle ABC$

$$\tan 45^\circ = \frac{AB}{BC}$$

$$1 = \frac{AB}{x}$$

$$AB = x \quad \dots(2)$$

From (1)

$$AB + 20 = \sqrt{3}AB$$

$$AB(\sqrt{3}-1) = 20$$

$$AB = \frac{20}{(\sqrt{3}-1)}$$

$$= \frac{20}{(\sqrt{3}-1)} \times \frac{(\sqrt{3}+1)}{(\sqrt{3}+1)}$$

$$= \frac{20(\sqrt{3}+1)}{3-1} = 27.32 \text{ cm}$$



Student's Favourite Academy

Shop No. 5, "Umang" Vasant Utsav C H S Ltd., Thakur Village, Kandivali E, Mumbai – 400 101 Phone : 8828132765, 9833035468
Email : favouriteacademy@gmail.com

From (2)

$$AB = x = 27.32\text{cm}$$

$$\text{Therefore } BC = x = AB = 27.32\text{cm}$$

$$\text{Therefore, } AB = 27.32\text{cm, } BC = 27.32\text{cm}$$

(ii)

$$\text{Let } BC = xm$$

$$BD = BC + CD = (x + 20)\text{ cm}$$

In $\triangle ABD$,

$$\tan 30^\circ = \frac{AB}{BD}$$

$$\frac{1}{\sqrt{3}} = \frac{AB}{x + 20}$$

$$x + 20 = \sqrt{3} AB \quad \dots(1)$$

In $\triangle ABC$

$$\tan 60^\circ = \frac{AB}{BC}$$

$$\sqrt{3} = \frac{AB}{x}$$

$$x = \frac{AB}{\sqrt{3}} \quad \dots(2)$$

From (1)

$$\frac{AB}{\sqrt{3}} + 20 = \sqrt{3} AB$$

$$AB + 20\sqrt{3} = 3AB$$

$$2AB = 20\sqrt{3}$$

$$AB = \frac{20\sqrt{3}}{2}$$

$$= 10\sqrt{3} = 17.32\text{cm}$$



Student's Favourite Academy

Shop No. 5, "Umang" Vasant Utsav C H S Ltd., Thakur Village, Kandivali E, Mumbai – 400 101 Phone : 8828132765, 9833035468
Email : favouriteacademy@gmail.com

From (2)

$$x = \frac{AB}{\sqrt{3}} = \frac{17.32}{\sqrt{3}} = 10 \text{ cm}$$

Therefore $BC = x = 10 \text{ cm}$

Therefore,

$AB = 17.32 \text{ cm}$, $BC = 10 \text{ cm}$

(iii)

Let $BC = xm$

$BD = BC + CD = (x + 20) \text{ cm}$

In $\triangle ABD$,

$$\tan 45^\circ = \frac{AB}{BD}$$

$$1 = \frac{AB}{x + 20}$$

$$x + 20 = AB \quad \dots(1)$$

In $\triangle ABC$

$$\tan 60^\circ = \frac{AB}{BC}$$

$$\sqrt{3} = \frac{AB}{x}$$

$$x = \frac{AB}{\sqrt{3}} \quad \dots(2)$$



Student's Favourite Academy

Shop No. 5, "Umang" Vasant Utsav C H S Ltd., Thakur Village, Kandivali E, Mumbai – 400 101 Phone : 8828132765, 9833035468
Email : favouriteacademy@gmail.com

From (1)

$$\begin{aligned}\frac{AB}{\sqrt{3}} + 20 &= AB \\ AB + 20\sqrt{3} &= \sqrt{3}AB \\ AB(\sqrt{3}-1) &= 20\sqrt{3} \\ AB &= \frac{20\sqrt{3}}{(\sqrt{3}-1)} \\ &= \frac{20\sqrt{3}}{(\sqrt{3}-1)} \times \frac{(\sqrt{3}+1)}{(\sqrt{3}+1)} \\ &= \frac{20\sqrt{3}(\sqrt{3}+1)}{3-1} = 47.32 \text{ cm}\end{aligned}$$

From (2)

$$x = \frac{AB}{\sqrt{3}} = \frac{47.32}{\sqrt{3}} = 27.32 \text{ cm}$$

$$\therefore BC = x = 27.32 \text{ cm}$$

Therefore,

$$AB = 47.32 \text{ cm}, BC = 27.32 \text{ cm}$$



Student's Favourite Academy

Shop No. 5, "Umang" Vasant Utsav C H S Ltd., Thakur Village, Kandivali E, Mumbai – 400 101 Phone : 8828132765, 9833035468
Email : favouriteacademy@gmail.com

Solution 18:

(i) From $\triangle APB$

$$\tan 30^\circ = \frac{AB}{PB}$$

$$\frac{1}{\sqrt{3}} = \frac{150}{PB}$$

$$PB = 150\sqrt{3} = 259.80m$$

Also, from $\triangle ABQ$

$$\tan 45^\circ = \frac{AB}{BQ}$$

$$1 = \frac{150}{BQ}$$

$$BQ = 150m$$

Therefore,

$$\begin{aligned}PQ &= PB + BQ \\ &= 259.80 + 150 \\ &= 409.80m\end{aligned}$$

(ii) From $\triangle APB$

$$\tan 30^\circ = \frac{AB}{PB}$$

$$\frac{1}{\sqrt{3}} = \frac{150}{PB}$$

$$\begin{aligned}PB &= 150\sqrt{3} \\ &= 259.80m\end{aligned}$$



Student's Favourite Academy

Shop No. 5, "Umang" Vasant Utsav C H S Ltd., Thakur Village, Kandivali E, Mumbai – 400 101 Phone : 8828132765, 9833035468
Email : favouriteacademy@gmail.com

Also, from $\triangle ABQ$

$$\tan 45^\circ = \frac{AB}{BQ}$$

$$1 = \frac{150}{BQ}$$

$$BQ = 150m$$

Therefore,

$$\begin{aligned}PQ &= PB - BQ \\ &= 259.80 - 150 \\ &= 109.80m\end{aligned}$$



Student's Favourite Academy

Shop No. 5, "Umang" Vasant Utsav C H S Ltd., Thakur Village, Kandivali E, Mumbai – 400 101 Phone : 8828132765, 9833035468
Email : favouriteacademy@gmail.com

Solution 19:

$$\text{Given } \tan x^\circ = \frac{5}{12} \quad \tan t^\circ = \frac{3}{4} \quad \text{and } AB = 48 \text{ m;}$$

Let length of $BC = xm$

From $\triangle ADC$

$$\tan x^\circ = \frac{DC}{AC}$$
$$\frac{5}{12} = \frac{DC}{48+x}$$

$$240 + 5x = 12CD \quad \dots(1)$$

Also, from $\triangle BDC$

$$\tan y^\circ = \frac{CD}{BC}$$
$$\frac{3}{4} = \frac{CD}{x}$$
$$x = \frac{4CD}{3} \quad \dots(2)$$

From (1)

$$240 + 5\left(\frac{4CD}{3}\right) = 12CD$$
$$240 + \frac{20CD}{3} = 12CD$$
$$720 + 20CD = 36CD$$
$$16CD = 720$$
$$CD = 45$$

Therefore, length of CD is 45 m.



Student's Favourite Academy

Shop No. 5, "Umang" Vasant Utsav C H S Ltd., Thakur Village, Kandivali E, Mumbai – 400 101 Phone : 8828132765, 9833035468
Email : favouriteacademy@gmail.com

Solution 20:

Since in a rhombus all sides are equal.

The diagram is shown below:

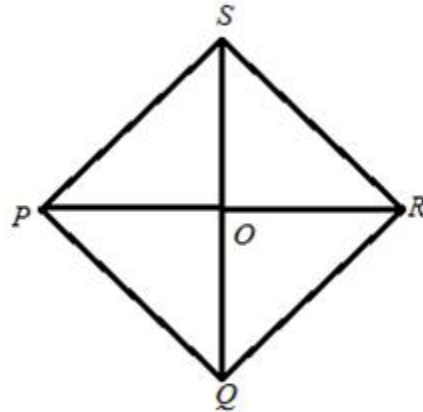

Therefore $PQ = \frac{96}{4} = 24 \text{ cm}$, Let $\angle PQR = 120^\circ$.

We also know that in rhombus diagonals bisect each other perpendicularly and diagonal bisect the angle at vertex.



Student's Favourite Academy

Shop No. 5, "Umang" Vasant Utsav C H S Ltd., Thakur Village, Kandivali E, Mumbai – 400 101 Phone : 8828132765, 9833035468

Email : favouriteacademy@gmail.com

Hence $\triangle POR$ is a right angle triangle and

$$\angle POR = \frac{1}{2}(\angle PQR) = 60^\circ$$

$$\sin 60^\circ = \frac{\text{Perp.}}{\text{Hypot.}} = \frac{PO}{PQ} = \frac{PO}{24}$$

But

$$\sin 60^\circ = \frac{\sqrt{3}}{2}$$

$$\frac{PO}{24} = \frac{\sqrt{3}}{2}$$

$$PO = 12\sqrt{3} = 20.784$$

Therefore,

$$PR = 2PO = 2 \times 20.784 = 41.568 \text{ cm}$$

Also,

$$\cos 60^\circ = \frac{\text{Base}}{\text{Hypot.}} = \frac{OQ}{24}$$

But

$$\cos 60^\circ = \frac{1}{2}$$

$$\frac{OQ}{24} = \frac{1}{2}$$

$$OQ = 12$$

Therefore, $SQ = 2 \times OQ = 2 \times 12 = 24 \text{ cm}$

So, the length of the diagonal $PR = 41.568 \text{ cm}$ and $SQ = 24 \text{ cm}$.